

DURA
MAKINA



**In the grain world
only the best
survive.**

Tahıl dñnyasında **sadece en iyiler**
hayatta kalır.



DURA
MAKINA

A success story

In this challenging way we started at 1996, we use the available sources in optimum way and ensure continuous improvement on products, respond our customers demands innovatively and flexibly.

DURA MAKINA always keeps up-to-date the systems and understandings and makes great effort for R&D works and enhances the quality since the foundation.

Bir başarı hikayesi

1996 yılında çıktığımız bu zorlu yolda mevcut kaynaklarımızı en verimli bir şekilde kullanarak ürün kalitesinde sürekli bir gelişim sağlıyor, müşterilerimizin taleplerine esnek ve yenilikçi çözümler sunuyoruz.

DURA MAKINA kurulduğu ilk günden beri AR-GE çalışmalarımız ile ürünlerimizi teknolojik olarak güncel tutuyor ve üretim sistemimizde her zaman kaliteyi artırarak inovatif ilerlemeler sağlıyoruz.

since
1996





We are always think innovative.

Biz her zaman inovatif düşünürüz.

We create value-added by offering production-oriented, custom engineered solutions. We are constantly working to improve the machines and systems in our production.

We are proud to be a company that contributes to the society and the environment without sacrificing quality in our products and services in the international arena.

We keep our technology up-to-date to produce flexible and innovative solutions to the demands of our customers.

As DURA MAKINA family, we are designing, designing and producing on grain processing technologies with our experienced team without sacrificing quality.

Biz üretim odaklı, özel mühendislik çözümleri sunarak katma değer oluşturuyoruz. Üretimimizde olan makina ve sistemleri her zaman daha da geliştirmek için durmadan çalışıyoruz.

Uluslararası arenada ürün ve hizmetlerimizde kaliteden ödün vermeden, topluma ve çevreye katkı sağlayan bir şirket olmaktan gurur duyuyoruz.

Müşterilerimizin taleplerine esnek ve yenilikçi çözümler üretmek için teknolojimizi güncel tutuyoruz.

DURA MAKINA ailesi olarak kaliteden ödün vermeden tecrübeli ekibimizle tahıl işleme teknolojileri üzerine tasarlıyor, projelendiriyor ve üretiyoruz.



**We add value
to life and
machine.**



**Biz hayata ve
makinaya deęer
katıyoruz.**



memnuniyet tahıl work satisfaction
grain başarı yenilikçi
SUCCESS tecrübe çalışkan
machinery innovative experience



UN PAKETLEME MAKİNASI Flour-Bran Packing Machine

DURA
MAKİNA

1-5 kg TEK TERAZİLİ
1-5 kg Single Weigher

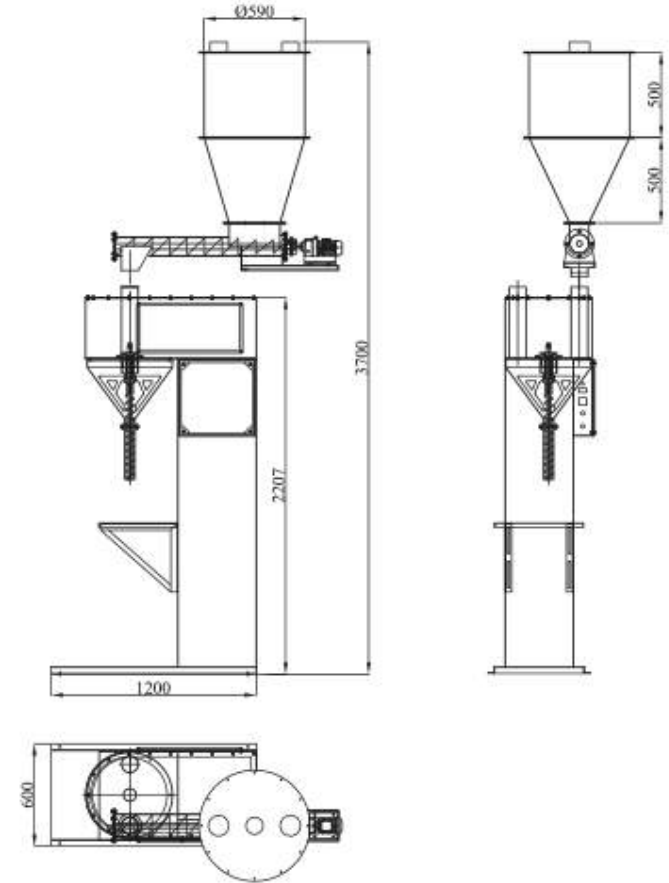

TARTIM KAPASİTESİ WEIGHING CAPACITY	ELEKTRİK TÜKETİMİ ELECTRICITY CONSUMPTION	ELEKTRİK ÇIKIŞI ELECTRICAL OUTPUT	HAVA BASINÇI AIR PRESSURE	BESLEME BUNKERİ HACMİ FEED VOLUME
UN:8-40 tor/dk FLOUR:8-40 bag/min.	4.5 kw/h	400V / 50-60Hz	6-8 bar	0.3m ³

TR

- Besleme helazonu,
- Yükseklik ayarlı torba sehbası,
- 1 kg paketi 1,5 saniyede doldurabilme,
- Elektronik sayac üzerinde kolay gramaj ayarı,

ENG

- Feeding screw,
- Height adjustable bag stand,
- 1 kg package: filling in 1.5 seconds,
- Easy weight adjustment on electronic counter,

UN PAKETLEME MAKİNASI

Flour Packing Machine

5-10 kg TEK - ÇİFT TARTIMLI
5-10 kg Single - Double Weigher

DURA
MAKİNA

PAKETLEME KANTARLARI
Packing Machines

www.duramakina.com.tr

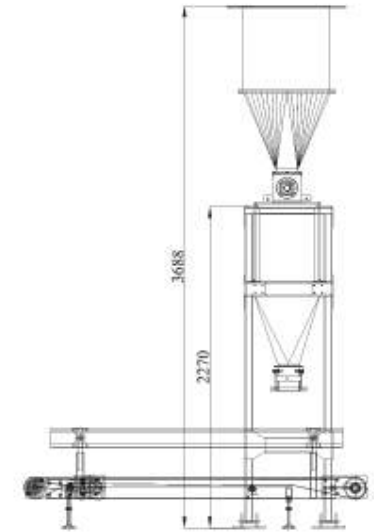
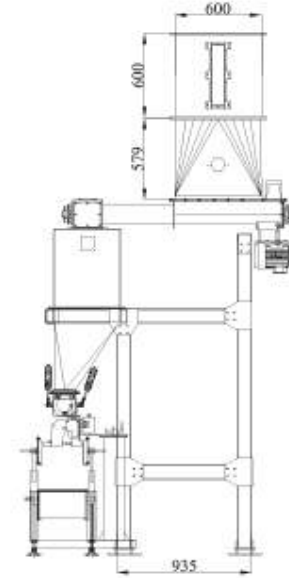
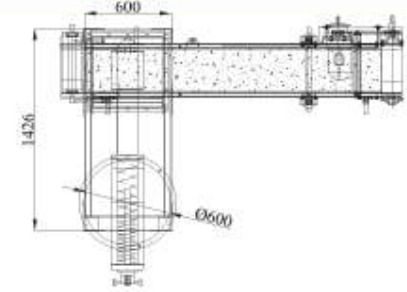
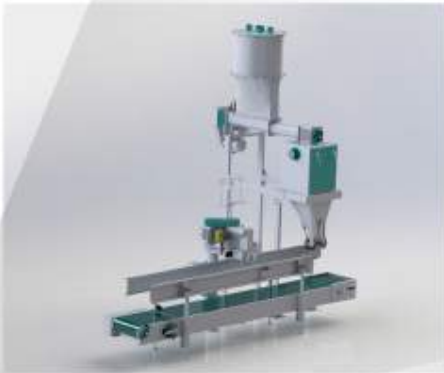

TARTIM KAPASİTESİ WEIGHING CAPACITY	ELEKTRİK TÜKETİMİ ELECTRICITY CONSUMPTION	ELEKTRİK ÇIKIŞI ELECTRICAL OUTPUT	HAVA TÜKETİMİ AIR CONSUMPTION	BESLEME BUNKERİ HACMI FEED VOLUME
TEK TARTIM : 5-7 tor/dk SINGLE WEIGHING: 6-8 bag/min.	3.2 (kw)	400 V/50-60 hz	6-8 bar	0.3 (m ³)
ÇİFT TARTIM : 10-12 tor/dk DOUBLE WEIGHING: 10-12 bag/min.	4.5 (kw)			

TR

- Çuval sıkıştırma ağız,
- Besleme helazonu,
- Taşıma platformu
- Dikiş bantı; manuel yükseklik ayarı,
- Dikiş makinası ayağı; manuel yükseklik ayarı
- Elektronik sistem dolun kontrolü
- Kullanılan silindireler FESTO markalıdır.

ENG

- Bag holding kit
- Feeding screw
- Machine frame
- Sewing belt; height-adjustable
- Sewing machine's leg is manually height-adjustable
- Electronical controller
- Cylinders are FESTO

UN-KEPEK PAKETLEME MAKİNASI Flour-Bran Packing Machine

DURA
MAKİNA

25-50 kg TEK TERAZİLİ
25-50 kg Single Weigher

PAKETLEME KANTARLARI
Packing Machines

www.duramakina.com.tr

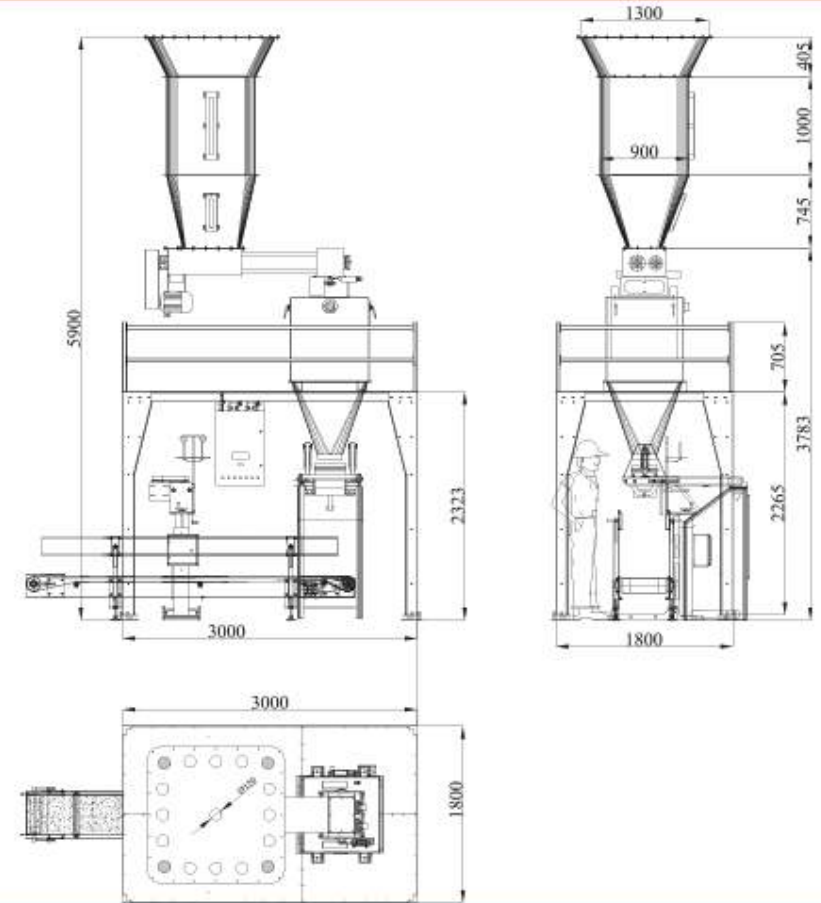

TARTIM KAPASİTESİ WEIGHING CAPACITY	ELEKTRİK TÜKETİMİ ELECTRICITY CONSUMPTION	ELEKTRİK ÇIKIŞI ELECTRICAL OUTPUT	HAVA BASINÇI AIR PRESSURE	BESLEME BUNKERİ HACMİ FEED VOLUME
UN:6-7 tor/dk FLOUR:6-7 bag/min.	6.5kw/h	400V / 50-60 Hz	6-8 bar	1.0 m ³

TR

- Çuval sıkıştırma vibratörü
- Besleme helezonu,
- Taşıma platformu
- Dikiş bantı; hidrolik sistem yükseklik ayarı,
- Dikiş makinası ayağı; manuel yükseklik ayarı
- Elektronik sistem dolum kontrolü
- Kullanılan silindirlere FESTO markalıdır.

ENG

- Bag holding vibrator
- Feeding screw
- Machine frame
- Sewing belt; hydrolically height-adjustable
- Sewing machine's leg is manually height-adjustable
- Electronical controller
- Cylinders are FESTO

UN PAKETLEME MAKİNASI Flour Packing Machine

DURA
MAKİNA

25-50 kg ÇİFT TERAZİLİ
25-50 kg Double Weigher

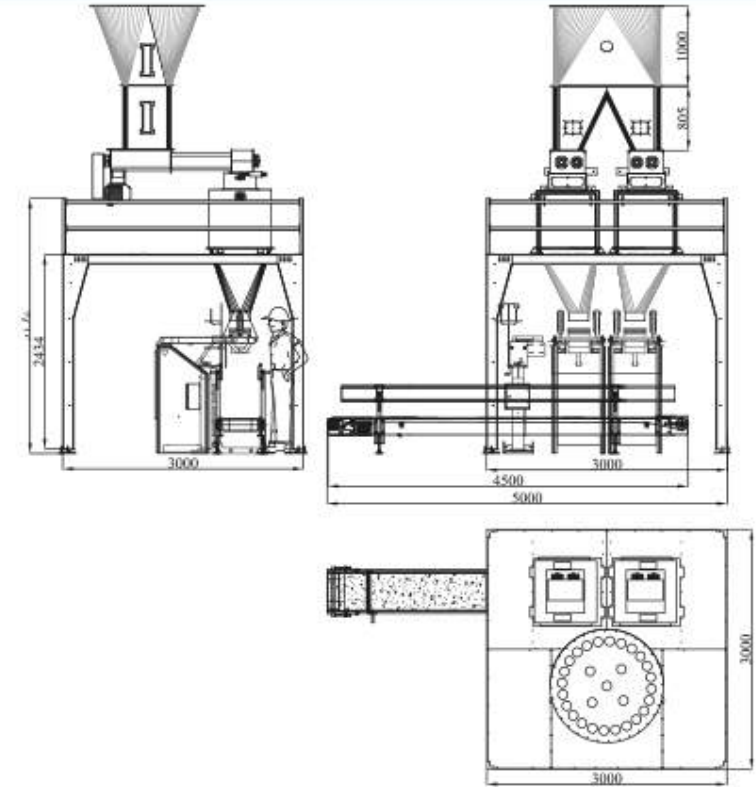

TARTIM KAPASİTESİ WEIGHING CAPACITY	ELEKTRİK TÜKETİMİ ELECTRICITY CONSUMPTION	ELEKTRİK ÇIKIŞI ELECTRICAL OUTPUT	HAVA BASINÇI AIR PRESSURE	BESLEME BUNKERİ HACMI FEED VOLUME
TEK TARTIM : 9-10 tor/dk SINGLE WEIGHING: 9-10 bag/min.	9,8kw/h	400 V/50-60 hz	6-8 bar	1,6(m ³)
ÇİFT TARTIM :12-14 tor/dk DOUBLE WEIGHING: 12-14 bag/min.	10,9kw/h			

TR

- Çuval sıkıştırma vibratörü
- Besleme helazonu,
- Taşıma platformu
- Dikiş bantı; hidrolik sistem yükseklik ayarı,
- Dikiş makinası ayağı; manuel yükseklik ayarı
- Elektronik sistem dolun kontrolü
- Kullanılan silindirlere FESTO markalıdır.

ENG

- Bag holding vibrator
- Feeding screw
- Machine frame
- Sewing belt; hydrolically height-adjustable
- Sewing machine's leg is manually height-adjustable
- Electronical controller
- Cylinders are FESTO

UN PAKETLEME MAKİNASI Flour Packing Machine

DURA
MAKİNA

25-50 kg ÇİFT TERAZİLİ 6 İSTASYONLU
25-50 kg Double Weigher 6 Station

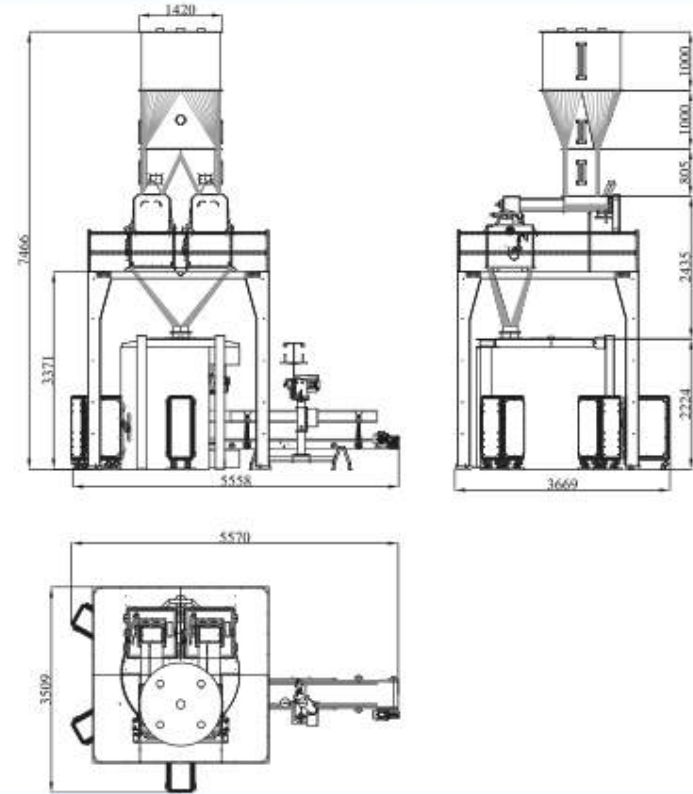
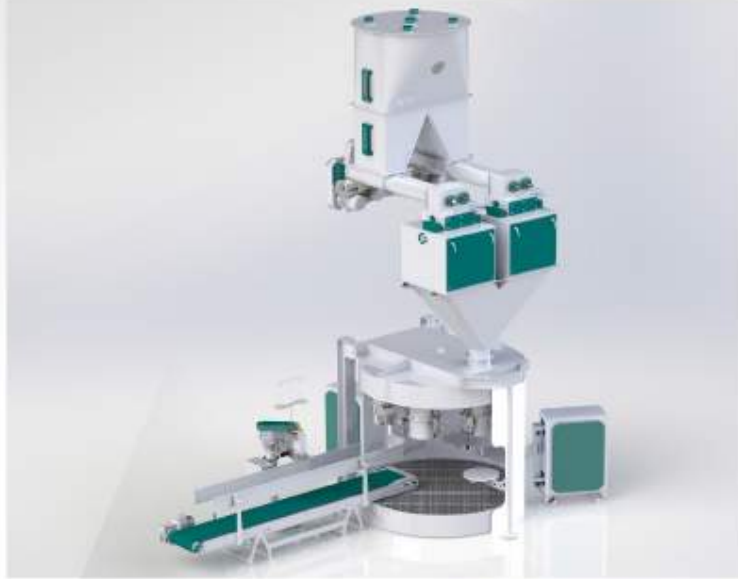

TARTIM KAPASİTESİ WEIGHING CAPACITY	ELEKTRİK TÜKETİMİ ELECTRICITY CONSUMPTION	ELEKTRİK ÇIKIŞI ELECTRICAL OUTPUT	HAVA BASINÇI AIR PRESSURE	BESLEME BUNKERİ HACMI FEED VOLUME
TARTIM : 13-15 ton/dk SINGLE WEIGHING: 13-15 bag/min.	14 kw/h	400 V/50-60 hz	6-8 bar	3 m ³

TR

- Çuval sıkıştırma vibratörü
- Besleme helazonu,
- Taşıma platformu
- Dikiş bantı; hidrolik sistem yükseklik ayarı,
- Dikiş makinası ayağı; manuel yükseklik ayarı
- Elektronik sistem dolum kontrolü
- Kullanılan silindirlere FESTO markalıdır.

ENG

- Bag holding vibrator
- Feeding screw
- Machine frame
- Sewing belt; hydrolically height-adjustable
- Sewing machine's leg is manually height-adjustable
- Electronical controller
- Cylinders are FESTO

VENTİL DOLUM MAKİNASI Valve Filling Machine

DURA
MAKİNA

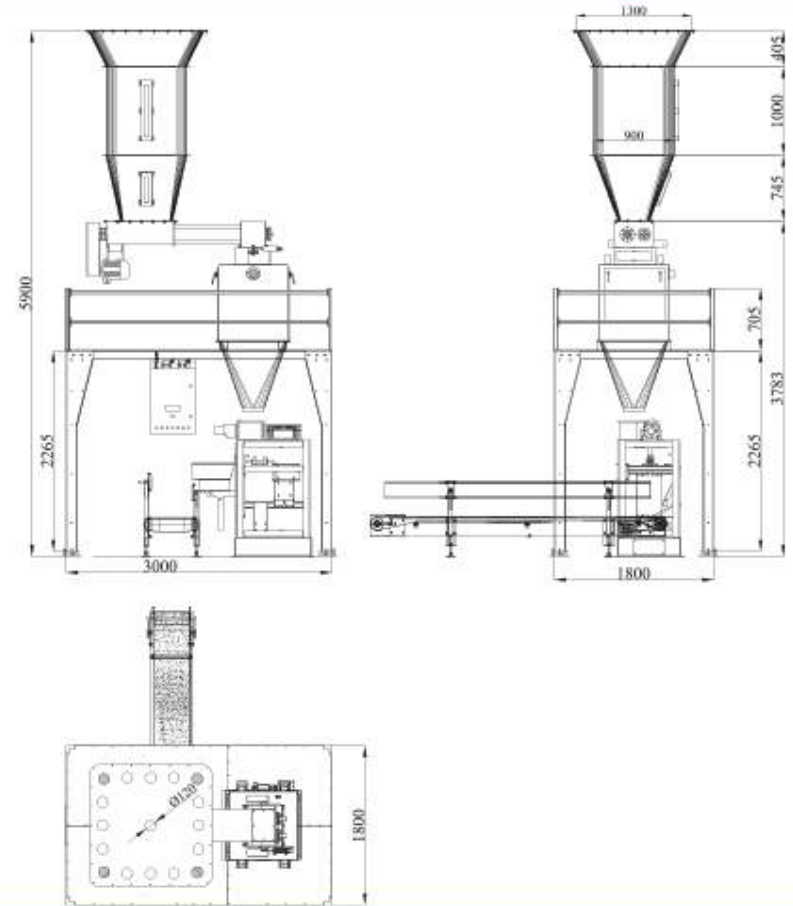

TARTIM KAPASİTESİ WEIGHING CAPACITY	TARTIM KAPASİTESİ ELECTRICITY CONSUMPTION	ELEKTRİK ÇIKIŞI ELECTRICAL OUTPUT	HAVA BASINÇI AIR PRESSURE	BESLEME BUNKERİ HACMİ FEED VOLUME
UN:4-5 tor/dk FLOUR:4-5 bag/min.	9.3 kw	400V / 50-60 Hz	6-8 bar	1.6 m ³

TR

- Torba sıkıştırma ağız
- Besleme helazonu,
- Taşıma platformu
- Taşıma bantı
- Dikiş makinası ayağı; manuel yükseklik ayarı
- Elektronik sistem dolm kontrolü
- Kullanılan silindirlere FESTO markalıdır.

ENG

- Bag holding kit
- Feeding screw
- Machine frame
- Transport belt
- Sewing machine's leg is manually height-adjustable
- Electronical controller
- Cylinders are FESTO

VENTİL DOLUM MAKİNASI Valve Filling Machine

DURA
MAKİNA

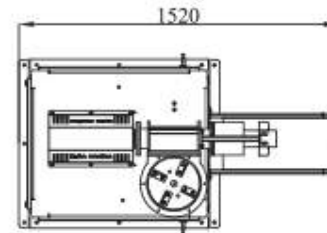
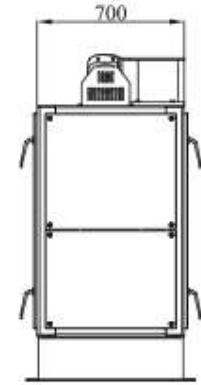
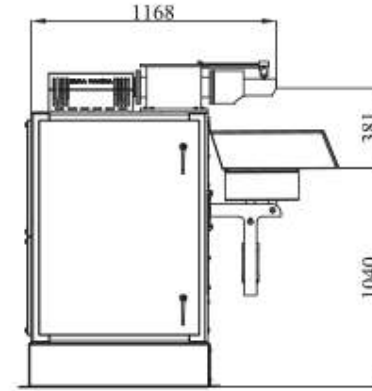

TARTIM KAPASİTESİ WEIGHING CAPACITY	ELEKTRİK TÜKETİMİ ELECTRICITY CONSUMPTION	ELEKTRİK ÇIKIŞI ELECTRICAL OUTPUT	HAVA BASINÇI AIR PRESSURE
UN:4-5 tor/dk FLOUR:4-5 bag/min.	6 kw	400V / 50-60 Hz	6-8 bar

TR

- Elektronik sistem dolum kontrolü
- Kullanılan silindirler FESTO markalıdır.

ENG

- Electronical controller
- Cylinders are FESTO

YEM PAKETLEME MAKİNASI Feed Packing Machine

DURA
MAKİNA

TEK- ÇİFT TERAZILI
Single-Double Weigher

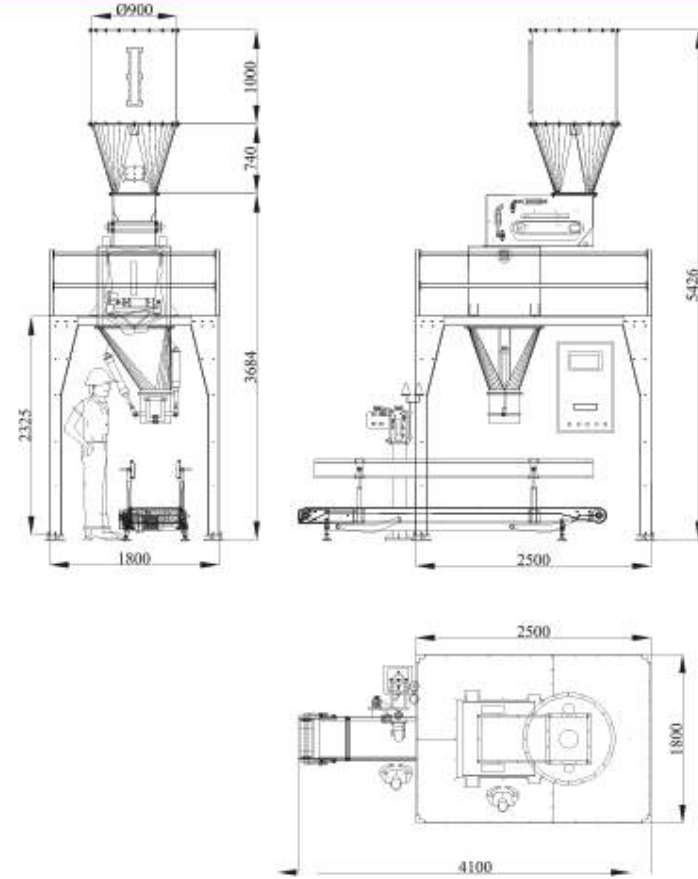

TARTIM KAPASİTESİ WEIGHING CAPACITY	ELEKTRİK TÜKETİMİ ELECTRICITY CONSUMPTION	ELEKTRİK ÇIKIŞI ELECTRICAL OUTPUT	HAVA BASINCI AIR PRESSURE	BESLEME BUNKERİ HACMİ FEED VOLUME
TEK TARTIM : 6-7 tor/dk SINGLE WEIGHING:6-7 bag/min.	3.5 kw /h	400 V/50-60 Hz	6-8 bar	0.9 (m ³)
ÇİFT TARTIM : 11-3 tor/dk DOUBLE WEIGHING:11-13 bag/min.	5 kw/h		6-8 bar	1.5 (m ³)

TR

- Çuval sıkıştırma ağızı,
- Besleme helazonu,
- Taşıma platformu
- Dikiş bantı; hidrolik sistem yükseklik ayarı,
- Dikiş makinası ayağı; manuel yükseklik ayarı
- Elektronik sistem dolum kontrolü
- Kullanılan silindirlere FESTO markalıdır.

ENG

- Bag holding kit
- Feeding screw
- Machine frame
- Sewing belt; hydrolically height-adjustable
- Sewing machine's leg is manually height-adjustable
- Electronical controller
- Cylinders are FESTO

TAHİL PAKETLEME MAKİNASI Grain Packing Machine

DURA
MAKİNA

TEK- ÇİFT TERAZİLİ
Single-Double Weigher

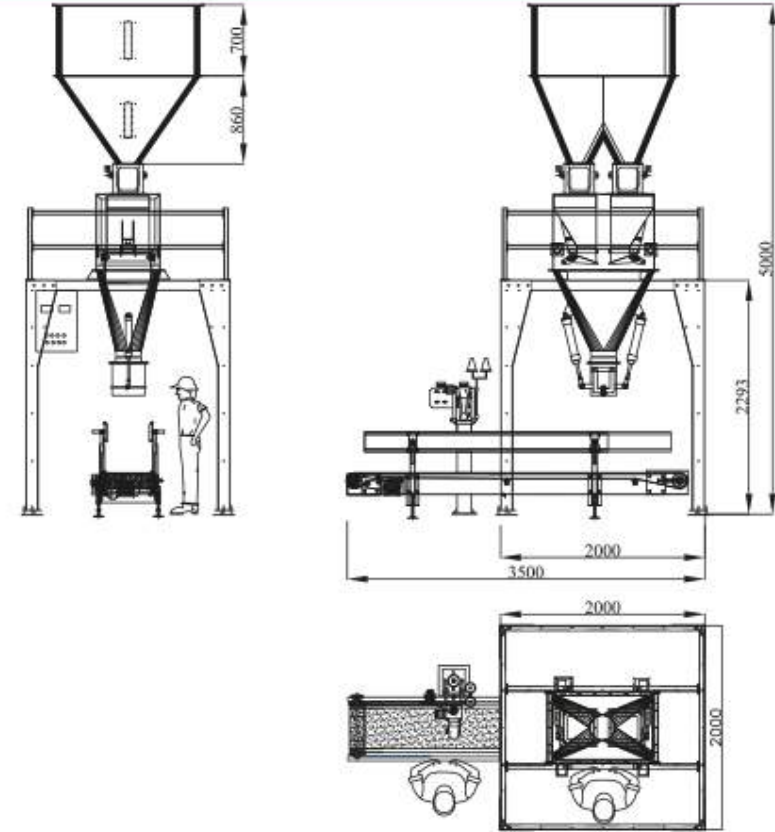

TARTIM KAPASİTESİ WEIGHING CAPACITY	ELEKTRİK TÜKETİMİ ELECTRICITY CONSUMPTION	ELEKTRİK ÇIKIŞI ELECTRICAL OUTPUT	HAVA BASINÇI AIR PRESSURE	BESLEME BUNKERİ HACMI FEED VOLUME
TEK TARTIM : 5-6 tor/dk SINGLE WEIGHING:5-6 bag/min.	2 kw /h	400 V/50-60 Hz	6-8 bar	0.6 (m ³)
ÇİFTTARTIM : 12-14 tor/dk DOUBLE WEIGHING:12-14 bag/min.	3 kw/h			2 (m ³)

TR

- Çuval sıkıştırma vibratörü
- Besleme helazonu,
- Taşıma platformu
- Dikiş bantı; hidrolik sistem yükseklik ayarı,
- Dikiş makinası ayağı; manuel yükseklik ayarı
- Elektronik sistem dolum kontrolü
- Kullanılan silindirlere FESTO markalıdır.

ENG

- Bag holding vibrator
- Feeding screw
- Machine frame
- Sewing belt; hydrolically height-adjustable
- Sewing machine's leg is manually height-adjustable
- Electronical controller
- Cylinders are FESTO

RANDIMAN GÖSTERGE SİSTEMİ
Extraction Rate Monitoring System

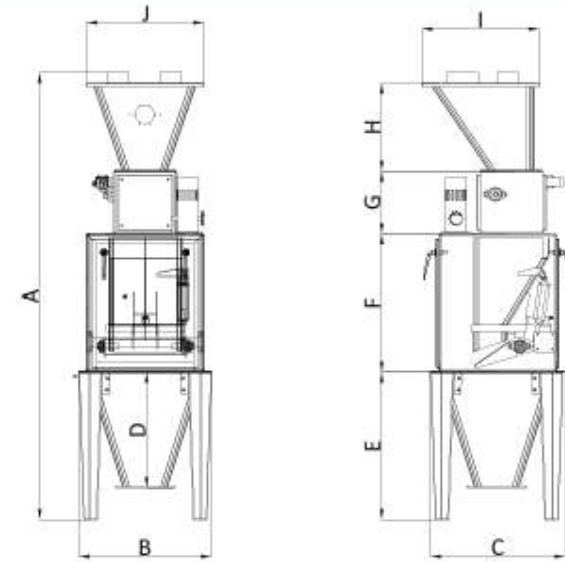

MODEL	A	B	C	D	E	F	G	H	I	K	KAPASİTE UN / FLOUR t/h	KAPASİTE BUĞDAY / WHEAT t/h	KAPASİTE KEPEK / BRAN t/h
DMRK-350	2131	630	640	550	703	660	298	420	559	559	6	8	3
DMRK-420	2221	710	715	550	695	758	298	420	559	559	10	12	5
DMRK-550	2565	850	850	785	900	897	298	420	559	559	17	25	8
DMRK-800	3306	1110	1110	700	955	1130	471	750	1000	1000	33	50	17

MODEL	ELEKTRİK TÜKETİMİ ELECTRICITY CONSUMPTION	ELEKTRİK ÇIKIŞI ELECTRICAL OUTPUT	HAVA BASINÇI AIR PRESSURE	BESLEME BUNKERİ HACMİ FEED VOLUME	DÖKÜŞ BUNKERİ HACMİ DUCT CONTAINER VOLUME
DMRK-350	1.5 kw/h	400V / 50-60 Hz	6-8 bar	0.06 m ³	0.07 m ³
DMRK-420	1.5 kw/h			0.06 m ³	0.08 m ³
DMRK-550	2 kw/h			0.06 m ³	0.11 m ³
DMRK-800	3 kw/h			0.4 m ³	0.3 m ³

TR

- PLC sistemli
- Tek ve ya network halinde çalışma
- Buğday kantarında kapasite ayarlama imkanı
- Geçmiş günlere ait verileri raporlama
- Merkezden bağımsız çalışabilme
- Kullanılan silindireler FESTO markalıdır.

ENG

- PLC system
- Able to work single or in network
- Capacity setting in wheat scale
- Reports the past dates
- Ability to work independently from center
- Cylinders are FESTO

MİKSER BESLEME TERAZİSİ
Mixer Feeding Scale

DURA
MAKİNA

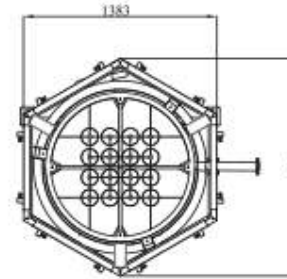
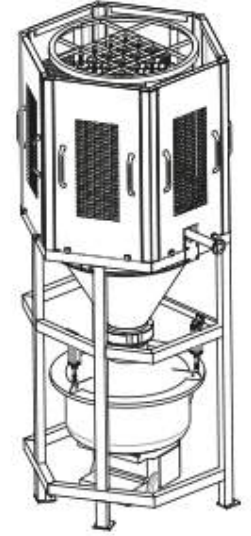
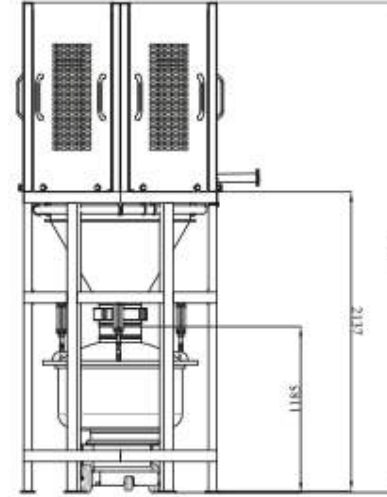

TR

- 200 kg tartım kapasitesinde
- Tamamen aisi-304(krom) malzemeden üretilmiş
- 12 adet 1000(mm) uzunluğunda polyester filtre
- Elektronik sistem dolım kontrolü
- Kullanılan silindirler FESTO markalıdır
- Ekmek fabrikaları ve unlu mamül imalatı yapan işletmelerde kullanılmaktadır

ENG

- 200 kg weighing capacity
- Made of aisi-304(krom) material completely
- 12 pcs of 1000(mm) long polyester filter
- Electronical controller
- Cylinders are FESTO
- It is used in bread factory and bakery products

DURAFLOW



BLOVER İSTASYONU Blower Station

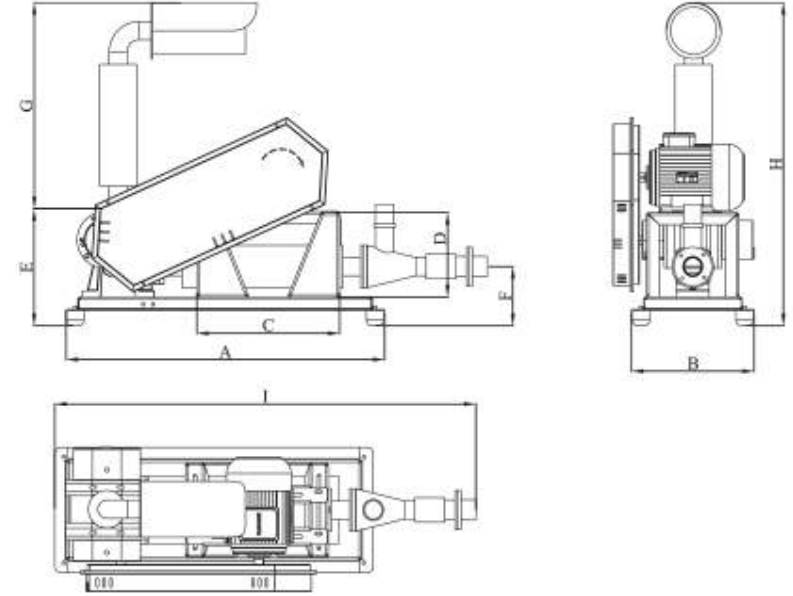

MODEL	A	B	C	D	E	F	G	H	I
DF-45	1070	415	480	277	385	195	680	1064	1415
DF-55	1075	505	484	280	395	198	680	1076	1436
DF-70	1075	545	487	280	395	206	680	1075	1458
DF-85	1240	605	570	280	443	209	810	1252	1650
DF-105	1230	690	574	280	430	210	825	1256	1675
DF-120	1650	605	700	420	585	300	1200	1785	2075
DF-135	1650	650	700	420	575	315	1200	1775	2100
DF-160	1650	720	700	420	560	315	1220	1780	2030
DF-200	2160	755	900	470	635	355	1300	2135	2685

TR

- Üç loblu, düşük deviri ve çift taraflı sıvı yağlamalıdır
- Dökme malzemeleri yatay ve dikey olarak alçak basınçla taşır

ENG

- Three lobed, low rpm, bilateral liquid lubrication
- Conveys bulk material horizontally and vertically with lower-pressure

EKLÜS
Rotary Valve

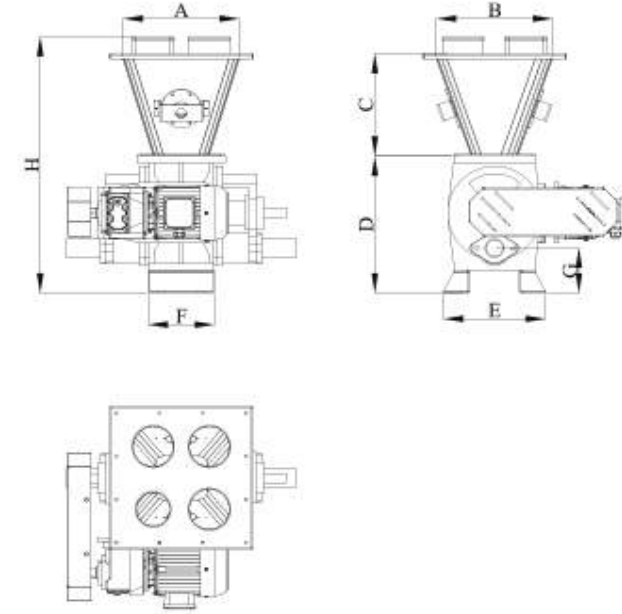

MODEL	A	B	C	D	E	F	H	G	KW	Kapasite (UN) t/h	Kapasite (KEPEK) t/h	Kapasite (BUGDAY) t/h
500x500	750	750	500	738	475	480	197	1310	1.5	50.0	28.0	85.0
450x450	650	650	450	620	420	440	172	1145	0.75	28.0	16.0	45.0
320x320	500	500	450	505	375	300	154	1035	0.55	12.5	6.5	20.0
250x250	400	400	400	450	315	275	135	825	0.55	5.5	3.0	10.0
200x200	350	350	350	400	300	195	132	825	0.37	2.2	1.5	4.0

TR

- Pük döküm gövde ve çelik tekerlekli
- Eklüs üst haznesi, dişlileri zincir muhafaza ve reductörleriyle pnömatak taşıma sistemleri ürünün boru hattına sürekli olarak beslenmesini sağlarnası
- Un irmik değirmenlerinde, yem değirmenlerinde, bisküvi, makarna ve ağaç işleme tesislerinde kullanılır.

ENG

- Cast iron body and steel rotor
- Together with upper hoper, chain safety guard, gearmotor. Provides continuous feeding of material to the pneumatic conveying line
- Used in flour and semolina mills, feed mills, biscuit and pasta plants, wood processing plants.

YÖN KLAPESİ Direction Flap

DURA
MAKİNA

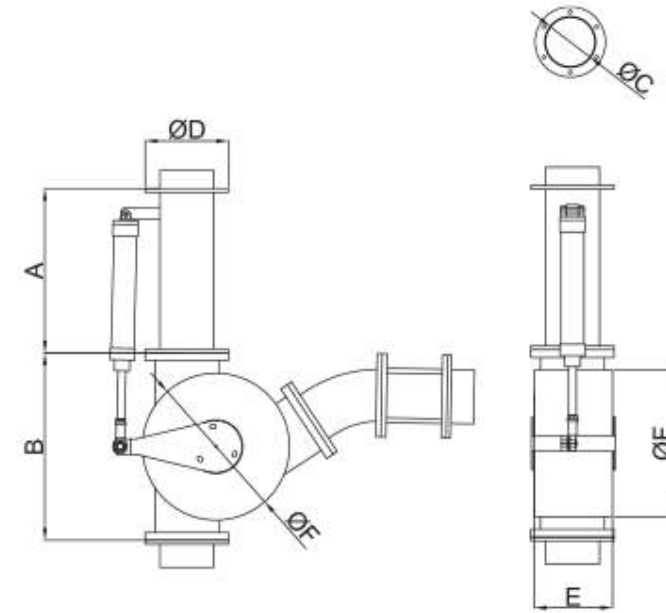

MODEL	A	B	ØC	ØD	E	ØF
YK 50	256	251	Ø54	Ø110	107	Ø179
YK 70	330	310	Ø69	Ø130	126	Ø225
YK 95	345	401	Ø103	Ø165	154	Ø267
YK 125	370	492	Ø121	Ø195	194	Ø370
YK 135	425	484	Ø133	Ø215	202	Ø380
YK 160	543	618	Ø163	Ø274	258	Ø485

TR

- Alüminyum döküm gövdeli ve çelik iç rotorlu
- Ø27mm-Ø168mm'lik çelik boru çaplarına göre imal edilebilmektedir
- İsteğe göre implus ventili
- Boru geçiş flanşlı

ENG

- Aluminum casting body and steel internal rotor
- Available for steel pipe diameters between Ø27mm-Ø168mm
- Impulse valve upon request
- With inlet/outlet flanges

AKTÜATÖRLÜ YÖN KLAPESİ Actuator Direction Flap

DURA
MAKİNA

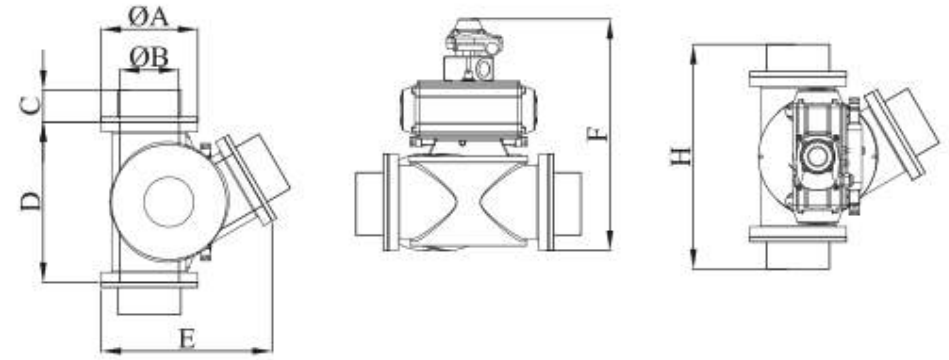
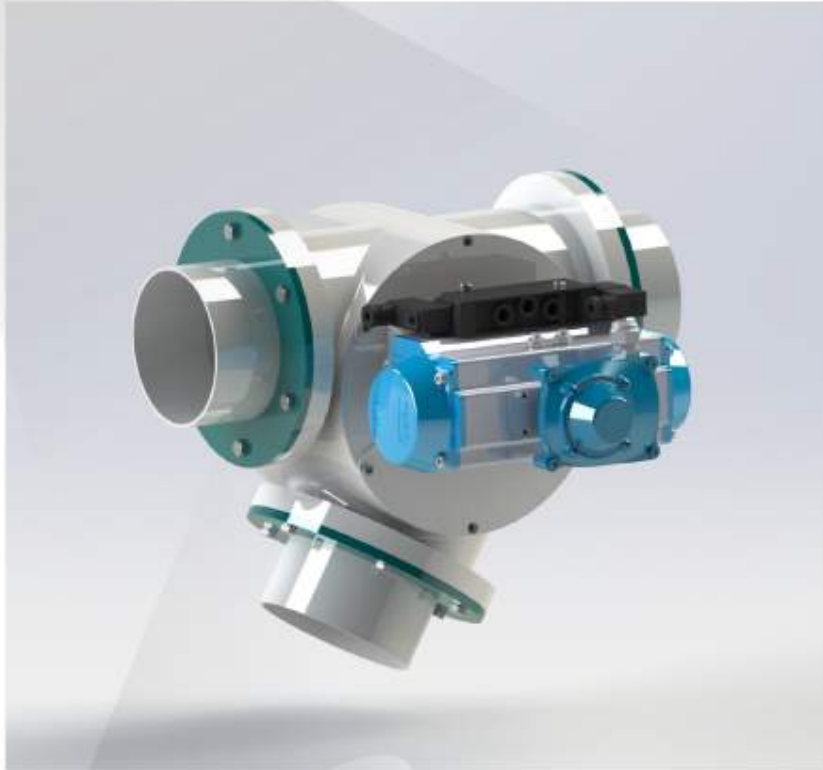

MODEL	ØA	ØB	C	D	E	F	H
YK 50	130	36-42 42-48 54-60	65	237	242	390	367
YK 70	130	64-70 70-76	65	237	242	390	367
YK 95	165	83-89 96-102	65	290	300	445	420
YK 120	195	102-108 108-114 121-127	65	324	345	460	454
YK 135	215	133-139	65	314	360	480	444
YK 160	240	153-159 162-168	65	381	413	525	511
YK 200	280	186-192 210-219	65	474	517	560	604

TR

- Alüminyum döküm gövdeli ve çelik iç rotorlu
- Ø42mm-Ø219mm'lik çelik boru çaplarına göre imal edilebilmektedir
- İsteğe göre implus ventili
- Boru geçiş flanşlı

ENG

- Aliminum casting body and steel internal rotor
- Available for steel pipe diameters between Ø42mm-Ø219mm
- Impulse valve upon request
- With inlet/outlet flanges

DURAFAN

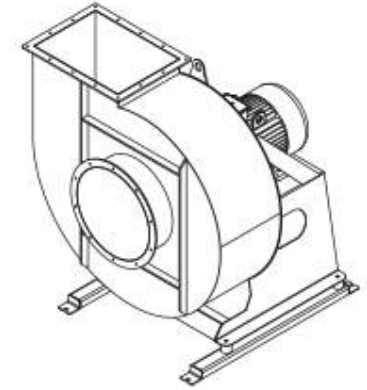
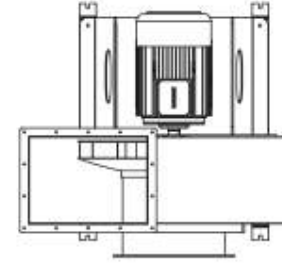
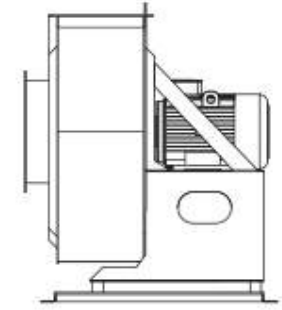
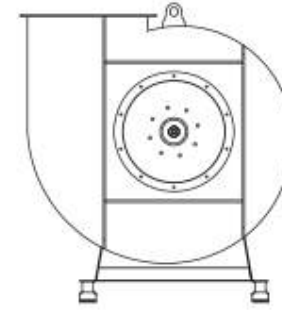
DURA
MAKİNAVANTİLATÖR
Ventilator

NOT: Aspiratör ebatları: debi ve basınç değerlerine göre değişiklik gösterip en uygun ebatlarda üretimi gerçekleşmektedir. Aspiratör yönleri, yukarıda verilen tabloya göre imal edilebilir.

TR

- Döner gövdeli (sağ ve sol yön 0°-315° arasında dönebilmektedir)
- Vibrasyon engelleyici lastik takozlu
- Statik ve dinamik balansı alınmış
- Gıda sektöründe faaliyet gösteren sanayi kuruluşlarında toz tutma ve nakil işlemlerinde kullanılır. debi ve basınç değerlerine göre modelleri tespit edilen aspiratörler farklı motor güçlerinde kullanılır. Özellikle gıda sektöründe tahılların temizlenmesinde ve işlenmesinde hava ile ürünlerin sınıflandırılmasında yardımcı olur

ENG

- Rotatable body (0° to 315°)
- With vibration proof rubber pads
- Statically and dynamically balanced
- Used for dust collection and transportation in industrial plants related to food. Ventilators, after choosing the models, are used with different motor powers according to requested flow rate and pressure. Especially in food sector for cleaning, processing or classifying grain.

ÇELİK UN / KEPEK SİLOSU

STEEL FLOUR/BRAN SILO

DURA
MAKİNA

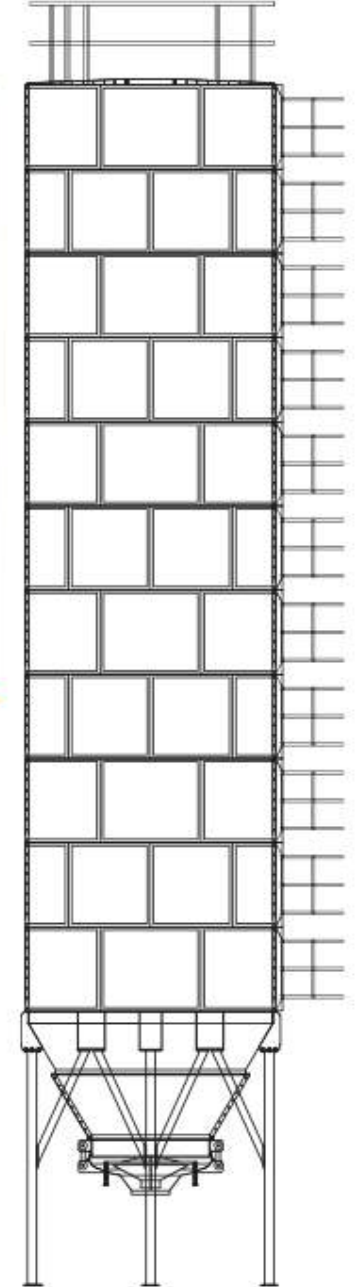
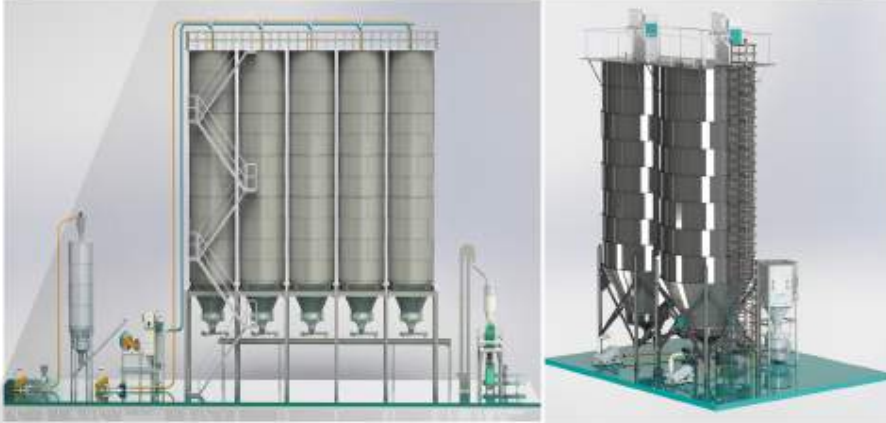

TR

- Vibro motorlu
- Silo boşaltma helazonu
- Silindir 3mm
- Konik 5mm ve 3mm
- Şapka 2mm
- Ayaklar 6mm kalınlıklı profilden
- Bina ve konstrüksiyon ölçülerine uygun çap ve boyda özel üretim olanağı sunulmaktadır
- Tüm yüzeyler kumlama işleminden sonra gıda kodeksine uygun epoksi boyalı olarak imal edilmektedir

ENG

- Vibration motor
- Silo discharge screw
- Cylinder thickness 3mm
- Cone thickness 3mm and 5mm
- Top cover thickness 2mm
- Feed made of 6mm thick profik
- Can be produced in demanded diameters and hieghts
- All surfaces are epoxy painted conforminty with food oodex after sand blasting process

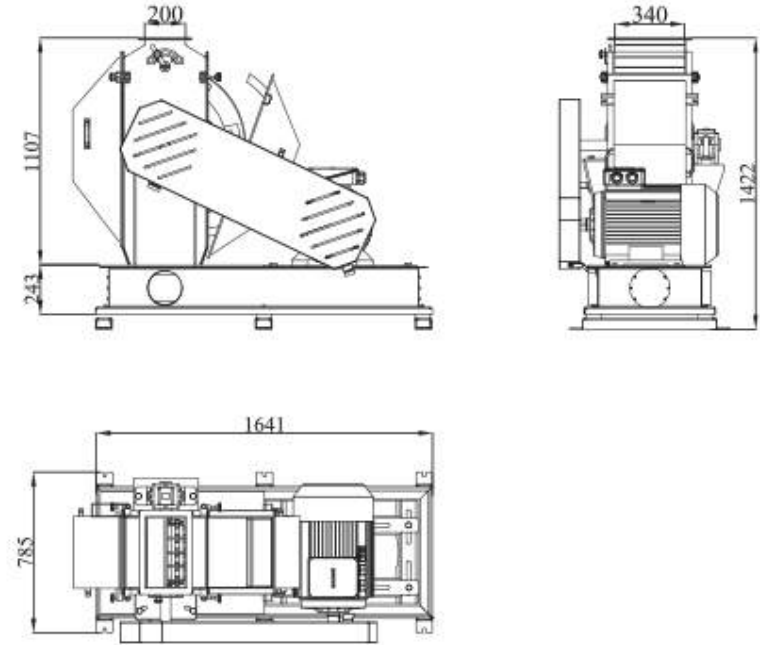
KAYIŞ KASNAK ÇEKİÇLİ DEĞİRMEN
BELT PULLEY WITH MILLDURA
MAKİNA

MODEL	MOTOR GÜCÜ (Kw)	MOTOR DEVRİ (rpm)	KAPASİTE (kg/saat) (kg/hour)
DMKCD - 30	30	1500	2000
DMKCD - 22	22	1500	1200

TR

- Motor bağlantı biçimi kayış kasnak tahrikidir
- Çekiçler sert st52 çelik malzemeden yapılmış ve ısı işleme tabi tutularak mukavemetli hale getirilmiştir
- Çekiçleri taşıyan rotor, kuvvetli bir mil üzerinde dönmektedir
- Çoğu taneli, kuru veya az rutubetli maddeler kolayca öğütebilmektedir

ENG

- Vee-belt driven
- Hammers are made of rigid st52 material and strengthened by heat-treatment
- The rotor which carries the hammers rotates on a strong shaft
- Most of material which are granular, dry or less-humid can easily be grinded

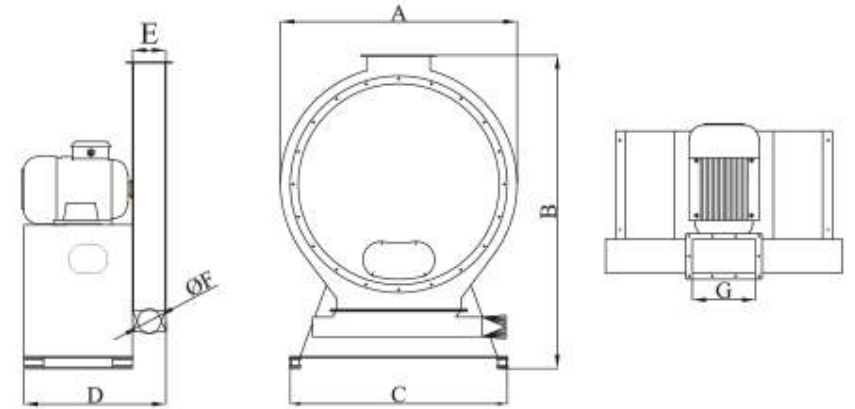
DİREK AKÜPLE ÇEKİÇLİ DEĞİRMEN
MOLD FLOWER HAMMER MILLDURA
MAKİNA

MODEL	A (mm)	B (mm)	C (mm)	D (mm)	E (mm)	F (mm)	G (mm)	MOTOR GÜCÜ (Kw)	MOTOR DEVİRİ (rpm)	KAPASİTE (kg/saat) (kg/hour)
DMDCD-18,5	1200	1680	1100	720	170	120	320	18,5	1500	700-1000

TR

- Motor bağlantı biçimi kayış aküple tahriklidir
- Çekiçler sert st52 çelik malzemeden yapılmış ve ısıtılarak mukavemetli hale getirilmiştir
- Çekiçleri taşıyan rotor, kuvvetli bir mil üzerinde dönmektedir
- Çoğu taneli, kuru veya az rutubetli maddeler kolayca öğütlebilmektedir

ENG

- Directly coupled driven
- Hammers are made of rigid st52 material and strengthened by heat-treatment
- The rotor which carries the hammers rotates on a strong shaft
- Most of material which are granular, dry or less-humid can easily be grinded

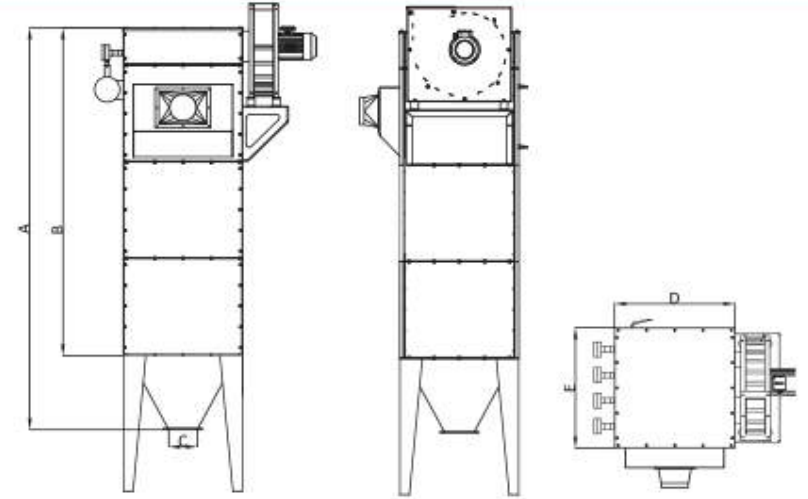
KARE JET FİLTRE
SQUARE JET FILTERDURA
MAKİNA

MODEL	TORBA SAYISI NUMBER OF BAGS	TORBA BOYU BAG LENGTH	A(mm)	B(mm)	C(mm)	D(mm)	E(mm)	YÜZEY ALAN(m ²) SURFACE AREA
DMJF-6	6	1000	1680	1300	135	450	620	2,3
		1200	1880	1500				2,7
		1800	2480	2100				4
		2400	3080	2700				5,4
DMJF-9	9	1000	1680	1300	135	620	620	3,4
		1200	1880	1500				4,1
		1800	2520	2100				6,1
		2400	3160	2700				8,1
DMJF-12	12	1000	1680	1300	135	620	790	4,5
		1200	1880	1500				5,4
		1800	2520	2100				8,1
		2400	3160	2700				10,8
DMJF-16	16	1000	1680	1300	135	790	790	6
		1200	1880	1500				7,2
		1800	2520	2100				10,8
		2400	3160	2700				14,5
DMJF-20	20	1000	1680	1300	135	960	790	7,5
		1200	1880	1500				9
		1800	2520	2100				13,6
		2400	3160	2700				18
DMJF-25	25	1000	1680	1300	135	960	960	9,5
		1200	1880	1500				11,3
		1800	2520	2100				17
		2400	3160	2700				22,5

TR

- Filtre torbalarının maksimum temizleme kapasitesi
- Temizlenmiş havanın yüksek verimde temizleme oranı
- Ürüne göre filtrenin yüklenim kapasitesi

ENG

- The max cleaning capacity for each filter bag
- The highest cleaning ratio of cleaned air
- The loading capacity of filter for each product

DiĐER MAKİNALAR
OTHER MACHINES



ÇUVAL TAŞIMA BANTI
SACK CONVEYING BELT

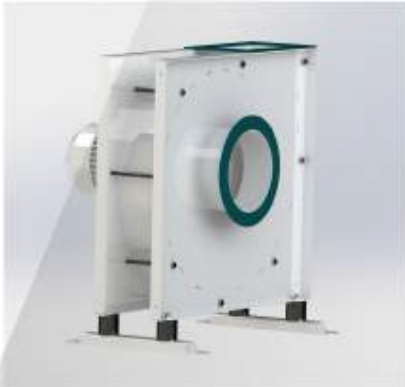

KARE TOZ ASPİRATÖR
SQUARE DUST FAN

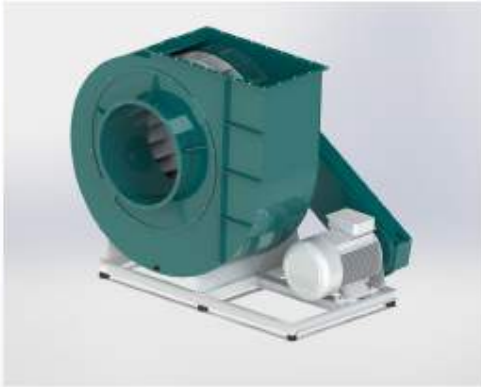

ARA YATAKLI TOZ ASPİRATÖR
V-BELT DRIVEN FAN



DÖRTLÜ VE ALTILI DAĞITICILAR - QUARTET AND SESTET DISTRUBITORS



ALTTAN ÜFLEMELİ EKLÜS - LOWER PIPE ROTARY VALVE



TÜP VİDA - TUBE SCREW



SİLO BOŞALTICI - SILO DISCHARGER



DURA[®]
MAKINA

ONLY the **BEST...**
sadece en iyiler...

www.duramakina.com.tr